

Appearance Patent No.: ZL 201830752892.X
CE certification: AT011611741E
FCC certification: AT011611742E
RoSH certification: 18300RC20410801

V1.8

MODBUS OUTPUT SINGLE/DUAL AXIS INCLINOMETER

SCA116T/SCA126T

Technical Manual

SCA116T/SCA126T MODBUS OUTPUT INCLINOMETER



PRODUCTION EXECUTION STANDARD REFERENCE

- Quality management system certification: GB/T19001-2016 idt ISO19001:2015 standard (Certificate No.: 128101)
- Quality management system certification: IATF16949: 2016 (Certificate No.: T178487)
- GJB9001C-2017 Standard Weaponry Quality Management System Certification (Registration number: 02622J31799R0M)
- Intellectual property management system certification: GB/T29490-2013 standard (Certificate No.: 41922IP00281-06R0M)
- High-tech Enterprise (Certificate No.: GR201844204379)
- ShenZhen Professional Dedicated Unique Innovative Enterprise(No.: SZ20210879)
- CE certification: AT011611741E
- FCC certification: AT011611742E
- RoSH certification: 18300RC20410801
- China National Intellectual Property Appearance Patent (Patent No.: ZL 201830752892.X)
- Revision time:2022-11-23

Note: Product functions, parameters, appearance, etc. will be adjusted as the technology upgrades.
Please contact our pre-sales business to confirm when purchasing.

SCA116T/SCA126T MODBUS OUTPUT INCLINOMETER



SCA INCLINOMETER

► PRODUCTION

SCA116T & SCA126T is the MODBUS output inclination sensor launched by RION Technology for industrial field control. It uses RS485 hardware differential bus to transmit data. Built-in high-precision 16bit A / D differential converter, through the 5th order filtering algorithm, can measure the tilt and pitch angle of the sensor output relative to the horizontal plane. built-in high-precision digital temperature sensor, the temperature drift of the sensor can be corrected according to the change of the built-in temperature sensor to ensure the high repeatability of the product in low temperature and high temperature environments. The output response frequency standard can be up to 18Hz. If a higher response frequency is needed, our company can customize it according to the user. The product belongs to a real industrial grade product, with reliable and stable performance, good scalability, and multiple output options. Suitable for various harsh industrial control environments.

► FEATURES

- ★ Single / dual axis inclination measurement
- ★ Two communication protocols are optional
- ★ Wide temperature operation -40 ~ + 85 °C
- ★ IP67 protection level
- ★ Direct lead interface
- ★ Range $\pm 1 \sim \pm 90^\circ$ optional
- ★ DC 9 ~ 36V wide voltage input
- ★ Resolution 0.01 °
- ★ High anti-vibration performance > 2000g

► APPLICATION

- ★ Satellite antenna searching
- ★ Radar vehicle platform detection
- ★ Geological equipment tilt monitoring
- ★ Ship navigation attitude measurement
- ★ Measurement of the initial firing angle of the artillery barrel
- ★ Direction measurement based on the inclination angle
- ★ Attitude detection of the satellite communication vehicle
- ★ Railway locomotive monitoring
- ★ Attitude navigation of underground drilling rig
- ★ Shield jacking application
- ★ Various construction machinery inclination measurement
- ★ Oil drilling equipment



SCA116T/SCA126T MODBUS OUTPUT INCLINOMETER

► SPECIFICATIONS

SCA116T/126T	CONDITION	PARAMETER				UNIT
Measure range		±10	±30	±60	±90	°
Measure axis		X Y	X Y	X Y	X Y	axis
Resolution		0.01	0.01	0.01	0.01	°
Measure accuracy	@25°C	0.02	0.03	0.05	0.06	°
Long term stability		0.05	0.05	0.05	0.05	°
Zero Temp.coefficient	-40 ~ 85°C	±0.006	±0.006	±0.006	±0.006	°/°C
Sensitivity temp-coeffi	-40 ~ 85°C	≤100	≤100	≤100	≤100	ppm/°C
Power on time		0.5	0.5	0.5	0.5	S
Response time		0.02	0.02	0.02	0.02	s
Output rate	5Hz、15Hz、35Hz、50Hz Optional					
communication protocol	MODBUS / ROIN 68 Optional					
EMC	According to EN61000 and GBT17626c					
MTBF	≥98000 hours/times					
Insulation Resistance	≥100MΩ					
Shockproof	100g@11ms、3 Axial Direction (Half Sinusoid)					
Anti-vibration	10grms、10 ~ 1000Hz					
Protection grade	IP67					
Cables	Standard as 1-meter length, wear-resistant, oil-proof, wide temperature, shielded cable 4 * 0.4mm2					
Weight	≤220g (including 1 meter cable)					

* This performance parameter only lists ± 10 °, ± 30 °, ± 60 °, ± 90 ° series as a reference, for other measurement ranges, please refer to the most adjacent parameters.

KEY WORDS

Resolution : Refers to the sensor in measuring range to detect and identify the smallest changed value.

Measure accuracy : Refers to in the normal temperature circumstances,the sensor absolute linearity, repeatability, hysteresis, zero deviation, and transverse error comprehensive error.

Long term stability : Refers to the sensors in normal temperature conditions, the deviation between the maximum and minimum values after a year's long time work.

Response time : Refers to the sensor in an angle change, the sensor output value reached the standard time required.

► ELECTRICAL PARAMETERS

PARAMETERS	CONDITION	MIN	TYPICAL	MAX	UNIT
Power supply voltage	Standard	9	12、24	36	V
	Optional		5		V
Working current	5V		42		mA
	12V		26		mA
	24		17		mA
Working temp.		-40		+85	°C
Store temp.		-40		+85	°C

SCA116T/SCA126T MODBUS OUTPUT INCLINOMETER

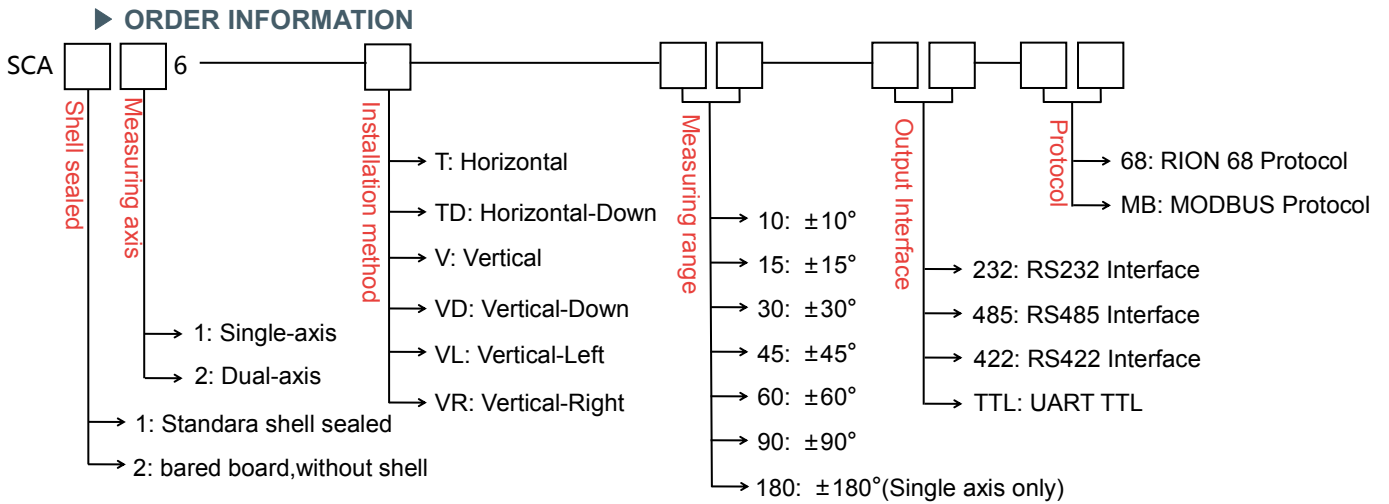

E.g: SCA126T-10-232-MB: Standara shell sealed / Dual-axis / Horizontal / $\pm 10^\circ$ measure range / RS232 interface / MODBUS protocol.

Note: The RS422 / TTL output interface is only for RION 68 protocol selection.

MECHANICAL PARAMETERS

- Connectors: 1m lead cable (customized)
- Enclosure material : Aluminum Oxide
- Installation : 4*M6 screws

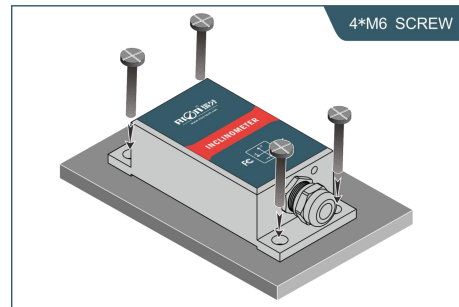

WORKING PRINCIPLE

Adopt imported core control unit and apply the principle of capacitive micro-pendulum. Using the principle of earth's gravity, when the tilting unit tilts, the earth's gravity will produce a gravitational component on the corresponding pendulum, and the corresponding electric capacity will change. By amplifying and filtering the electric capacity, the inclination angle is obtained after conversion.

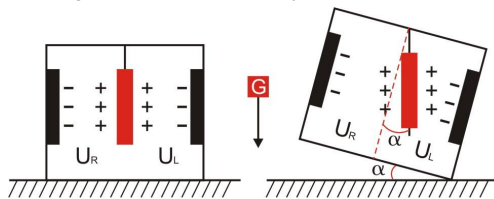

U_R, U_L respectively is the pendulum left plate and the right plate corresponding to their respective voltage between the electrodes, when the tilt sensor is tilted, U_R, U_L will change according to certain rules, so $f(U_R, U_L)$ on the inclination of α function:

$$\alpha = f(U_R, U_L)$$

ELECTRICAL CONNECTION

RS485 / RS232 / TTL standard shell wiring definition

	BLACK	WHITE	GREEN	RED
Thread color function	GND Power Negative	RS232(RXD) /TTL(RXD) RS485(D+)	RS232(TXD) /TTL(TXD) RS485(D-)	DC9 ~ 36V Power Positive

SCA116T/SCA126T MODBUS OUTPUT INCLINOMETER

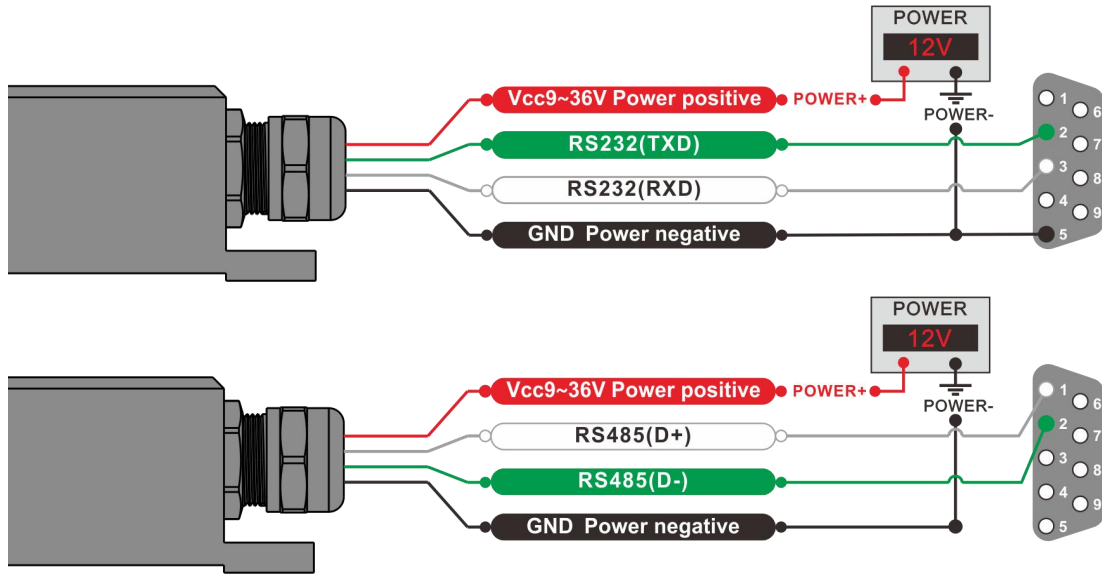

RS485/RS232/TTL single board wiring definition

Thread color function	RED	BLACK	WHITE	YELLOW
	DC9 ~ 36V Power Positive	GND Power Negative	RS232(TXD) /TTL(TXD) RS485(D-)	RS232(RXD) /TTL(RXD) RS485(D+)

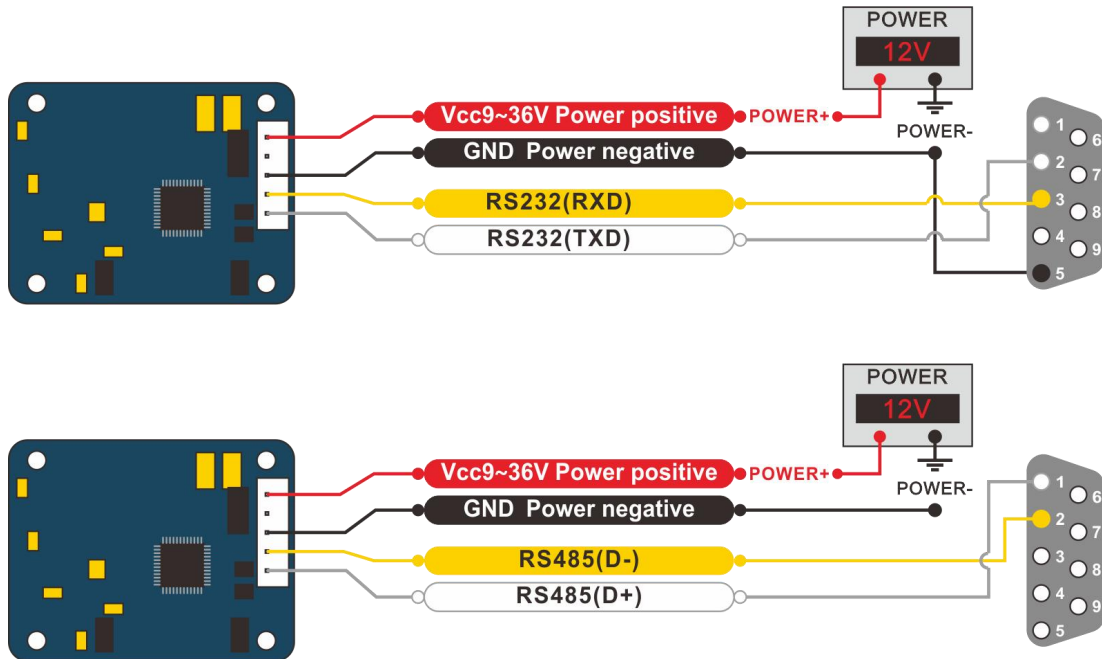

RS422 standard shell wiring definition

Thread color function	RED	BLACK	ORANGE	YELLOW	BLUE	WHITE
	DC9 ~ 36V Power Positive	GND Power Negative	RXD+	RXD-	TXD+	TXD-

SCA116T/SCA126T MODBUS OUTPUT INCLINOMETER

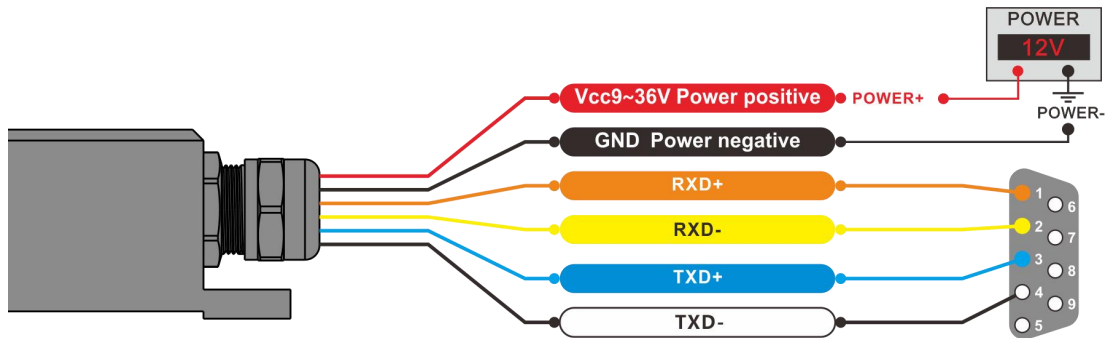

► DIMENSION

MODULE SIZE

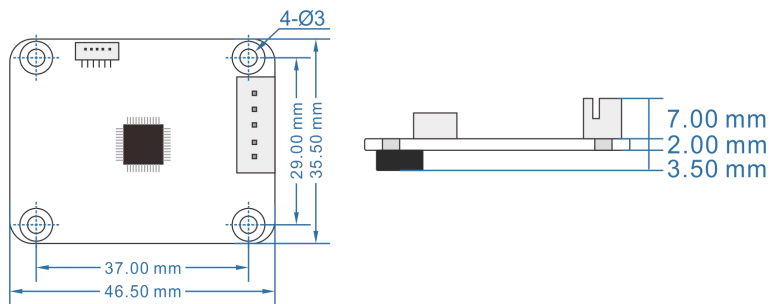

PCBA size: L46.5×W35.5×H12.5mm

Installation size: L37×W29×H2mm

outing screws: 4 M3 screws

DIMENSION WITH HOUSING

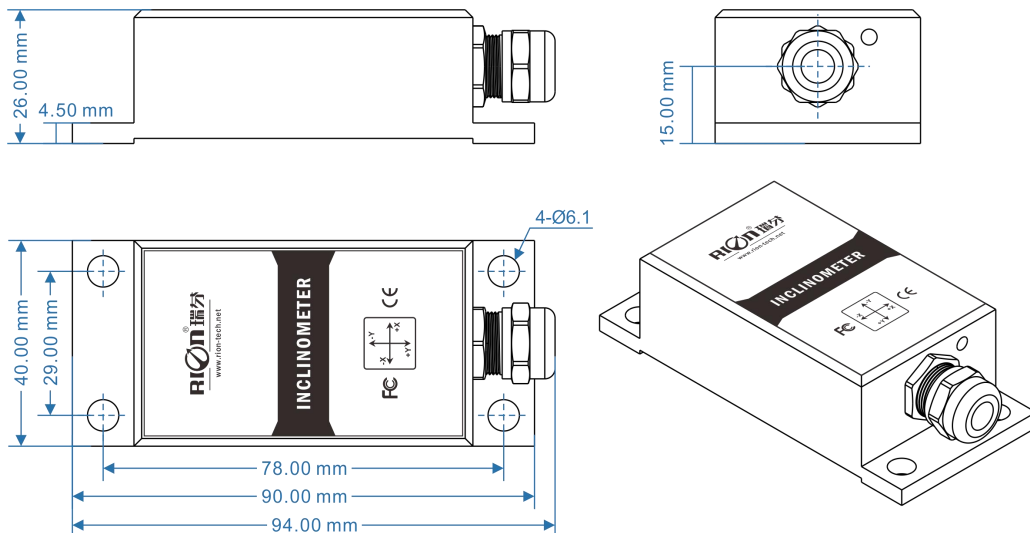

Shell size: L94×W40×H26mm

Installation size: L78×W29×H4.5mm

outing screws: 4 M6 screws

► INSTALLATION PRECAUTIONS

Please install the tilt sensor according to the correct method. Improper installation will cause measurement error. Pay attention to the first "surface" and the second "line":

- 1) The mounting surface of the sensor and the measured surface must be tight, flat and stable. The unevenness of the mounting surface is easy to cause the angle error of the sensor measurement.
- 2) The axis of the sensor and the axis to be measured must be parallel, and the angle between the two axes should be avoided as much as possible.

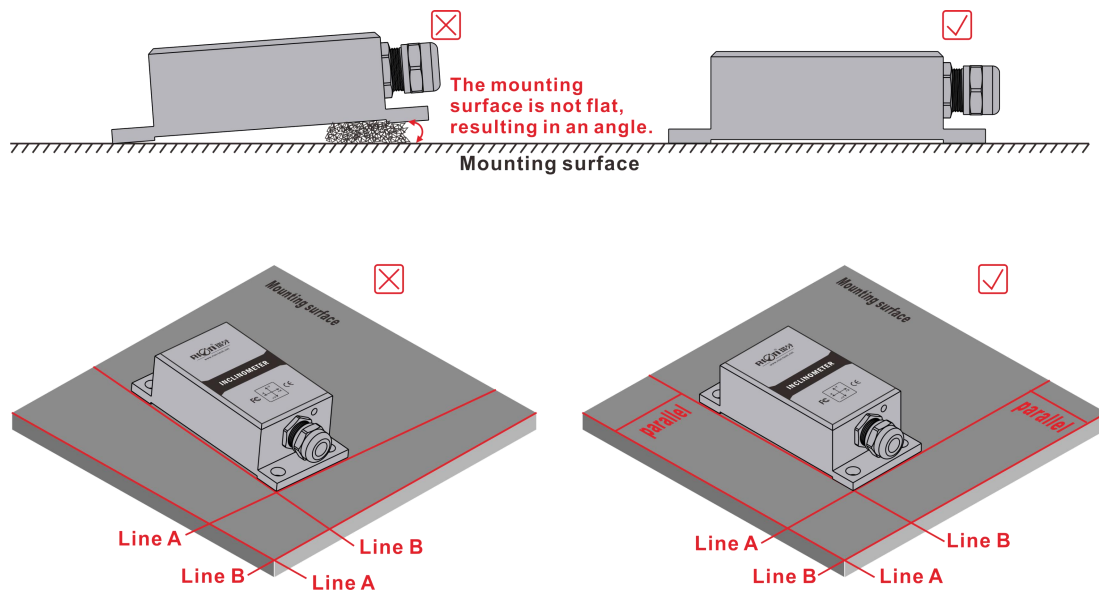

► INSTALLATION DIRECTION

During installation, keep the sensor mounting surface parallel to the target surface to be measured, and reduce the impact of dynamics and acceleration on the sensor. This product can be installed horizontally or vertically, please refer to the following diagram for the installation method:

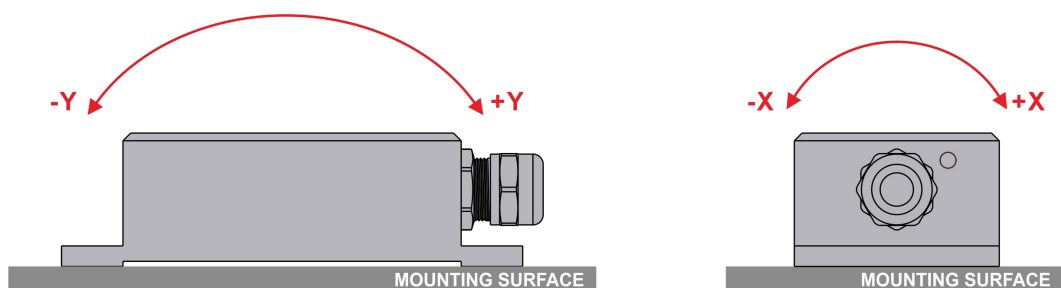

Horizontal installation

SCA116T/SCA126T MODBUS OUTPUT INCLINOMETER

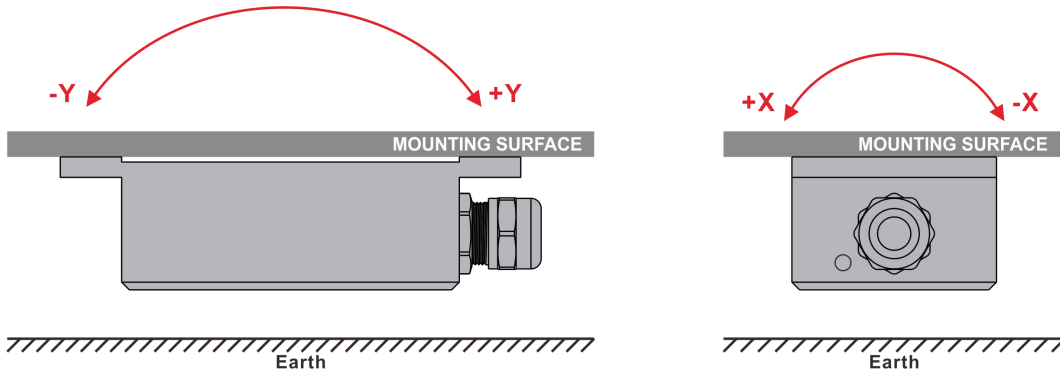

Horizontal-down installation

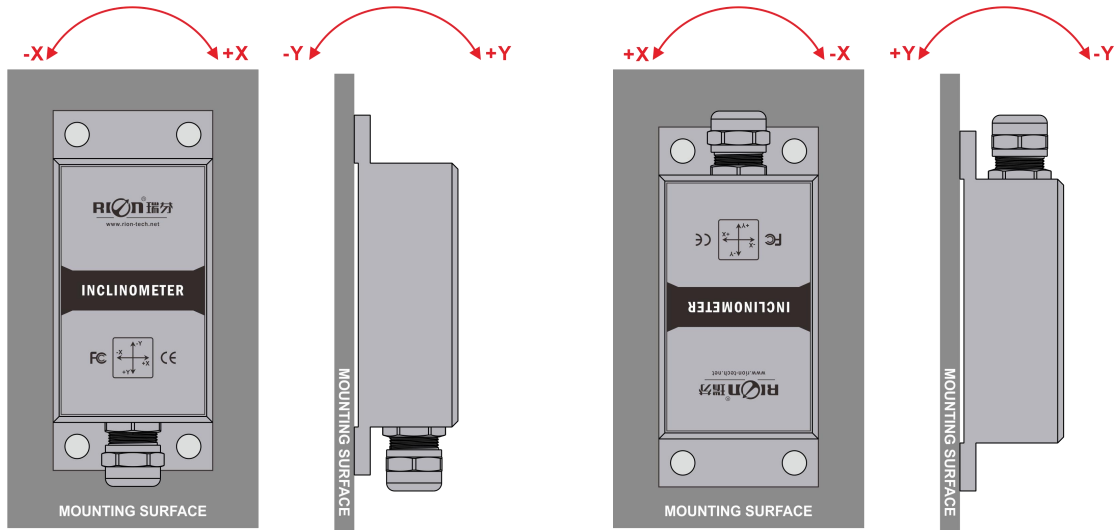

Vertical installation

Vertical-down installation

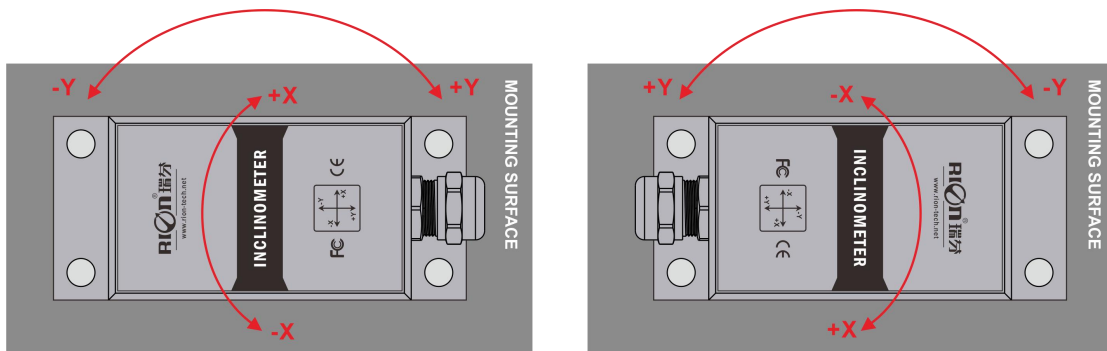

Vertical-left installation

Vertical-right installation

► **COMMUNICATION PROTOCOL**

1. Data frame format: (8 data bits, 1 stop bit, no check, default rate 9600)

Identifier (1byte)	Data length (1byte)	Address code (1byte)	Command word (1byte)	Data field	checksum (1byte)
68					

Data format: hexadecimal

Identifier: fixed at 68

Data length: the length from data length to checksum (including checksum)

Address code: the address of the acquisition module, the default is 00

The data field changes according to the different content and length of the command word.

Checksum: The sum of data length, address code, command word and data field does not consider carry

2. The command word analysis

Command word	Meaning/ Example	Description
0X01	Read X axis angle command example: 68 04 00 01 05	Data field (0byte) No data field command
0X81	Sensor response reply E.g: 68 07 00 81 10 26 80 3E	The data field (3byte) SA AA BB data field is a 3-byte return angle value, which is a compressed BCD code, S is the sign bit (0 positive, 1 negative), AAA is a three-digit integer value, and BB is a decimal value. The other axis data is the same. Such as 102680 means -26.8°.
0X02	Read Y axis angle command E.g: 68 04 00 02 06	Data field (0byte) No data field command
0X82	Response command read Y axis angle Sensor response reply E.g: 68 07 00 82 00 66 25 11	The data field (3byte) SA AA BB data field is a 3-byte return angle value, which is a compressed BCD code, S is the sign bit (0 positive, 1 negative), AAA is a three-digit integer value, and BB is a decimal value. The other axis data is the same. For example, 006625 means 066.25°.
0X04	Read X and Y angle commands simultaneously E.g: 68 04 00 04 08	Data field (0byte) No data field command
0X84	Sensor response reply E.g: 68 0D 00 84 00 20 10 10 05 25 00 50 50 9B	Data field (9byte) SA AA BB SC CC DDSE EE FF SA AA BB: 3 characters represent the X axis SC CC DD: 3 characters represent Y axis SE EE FF: The internal temperature value of 3 characters of the product, the analysis method is the same as the X-axis angle. Angle format is the same as X axis or Y axis The angle in the left example is: X axis 20.10 degrees, Y axis -5.25 degrees, temperature: +50.5°C
0X05	Set relative/absolute zero: You can set the current angle to zero degrees for relative measurement, or you can set it	Data field (1byte) 00: absolute zero 01: relative zero

SCA116T/SCA126T MODBUS OUTPUT INCLINOMETER

	back to the absolute factory zero degree, save after power off E.g: 68 05 00 05 00 0A	
0X85	Sensor response reply command E.g: 68 05 00 85 00 8A	Data field (1byte) The number in the data field indicates the result of the sensor response 00: set successfully FF: setting failed
0X0B	Set communication speed E.g: 68 05 00 0B 03 13 This command is set to take effect after power off and restart, and save function at power off	Data field (1byte) Baud rate: 00 means 2400 01 means 4800 02 means 9600 03 means 19200 04 means 115200 05 means 38400 the default value is 9600.
0X8B	Sensor response reply command E.g: 68 05 00 8B 90	Data field (1byte) The number in the data field indicates the result of the sensor response 00 Success FF Failure
0X0C	Set sensor output mode Response system: The upper computer needs to send read the angle command before the sensor reply the relative angle Automatic output system: After the sensor is powered on, X, Y angles are automatically output, and the output frequency is set as shown in the table on the right. (This function can be saved after power off) E.g: 68 05 00 0C 00 11	Data field (1byte) The factory default value is: 00 00 response system 01 5Hz automatic output mode 02 15Hz automatic output mode 03 25Hz automatic output mode 04 35Hz automatic output mode 05 50Hz automatic output mode Note: RS485 only has response mode with no automatic output mode
0X8C	Sensor response reply command E.g: 68 05 00 8C 00 91	Data field (1byte) The number in the data field indicates the result of the sensor response 00 Success FF Failure
0X0F	Set module address command The default address of the sensor is 00, 1.If multiple sensors are connected to a group of buses at the same time, such as RS485, each sensor needs to be set to a different address to achieve separate control and response angles. 2.If the new address is successfully changed, the address code in all subsequent commands	Data field (1byte) XX module address, the address ranges from 00 to EF. Note: All products have a common address: FF. If you forget the set address during the operation, you can use the FF address to operate the product and still respond normally.

SCA116T/SCA126T MODBUS OUTPUT INCLINOMETER

	<p>and response packets must be replaced with the new address code after the change to be effective, otherwise the sensor will not respond to the command. This command is a power-off save function.</p> <p>E.g: 68 05 00 0F 01 15 Set the address to 01.</p> <p>68 05 FF 0F 00 13 Reset the general address FF to 00</p>	
0X8F	<p>Sensor response reply command E.g: 68 05 00 8F 94</p>	<p>Data field (1byte), The number in the data field indicates the result of the sensor response 00 Success FF Failure</p>
0X0D	<p>Query relative/absolute zero Used to query whether the current zero-degree mode of the sensor is relative zero or absolute zero E.g: 68 04 00 0D 11</p>	<p>Data field (0byte) No data field command</p>
0X8D	<p>Sensor response reply command E.g: 68 05 00 8D 00 92</p>	<p>Data field (1byte), The number in the data field indicates the result of the sensor response 00 Absolute zero 01 Relative zero</p>

► **RION MODBUS COMMUNICATION PROTOCOL**

Note, please read the following items carefully before use:

1) Because the MODBUS protocol stipulates that between two data frames should be at least more than 3.5 bytes time (for example, at 9600 baud rate, the time is $3.5 \times (1/9600) \times 11 = 0.004s$). But in order to leave enough margin, this sensor increases this time to 10ms, so please leave at least 10ms time interval between each data frame.
 The host sends the command-10ms idle-the slave responds to the command-10ms idle-the host sends the command ...

2) MODBUS protocol stipulates the broadcast address ---- relevant content of 0. This sensor can also accept the content of the broadcast address, but will never reply. Therefore, the broadcast address 0 can be used for the following purposes, for reference only.

1. Set the addresses of all tilt sensors of this model mounted on the bus to a certain address.
2. Set all tilt sensors of this model mounted on the bus to relative / absolute zero.
3. Test this type of sensor on the entire bus, that is, the host sends a 0 address query angle command to the bus, and the communication indicator flashes when the communication is normal.
- 3) In order to improve the reliability of the system, set address command and set absolute / relative command, both commands must be sent twice in order to be effective. "Two consecutive transmissions" means that both transmissions are successful (the slave has a reply each time), and the two questions and answers must be consecutive, that is, the master cannot insert other data frames in the middle of the two questions and answers, otherwise, this kind of command It will be locked until the power is turned off. The setting process is as follows:
 Send setting address command-wait for setting success command sent by slave-(no other commands can appear) Send setting address command again-wait for setting success command sent by slave-modification successful
- 4) After power on, the above two setting commands can only be set once, if you need to set again, you need to power off and power on again.
- 5) When the normal communication has accumulated to a certain number of times, the communication indicator will flash once.

1. Data frame format:

RTU mode

Communication parameters: Baud rate 9600 bps

Data frame: 1 start bit, 8 data, even parity, 1 stop bit

2. Reading angle data:

Modbus function code 03H

Master query command :		Slave response :	
Sensor address	01H	Sensor address	01H
function code	03H	function code	03H
Access register	00H	Data length 8 bytes	08H
first address	02H	Data word 1 lower 8 bits	50H
Data length	00H	Data word 1 high 8 bits	46H
4 bytes	04H	Data word 2 lower 8 bits	00H
CRC	E5C9H	Data word 2 high 8 bits	00H
		Data word 3 lower 8 bits	23H
		Data word 3 lower 8 bits	20H
		Data word 4 high 8 bits	00H
		Data word 4 lower 8 bits	00H
		CRC	BD61H

Read measurement data command example 1 :												
Host sends				01 H	03 H	00 H	02 H	00 H	04 H	E5H	C9H	
Slave response												
01H	03 H	08 H	50 H	46 H	00 H	00 H	23H	20 H	00H	00 H	BDH	61H

Note: The data field of the slave reply frame is 50H, 46H, 00H, 00H, 23H, 20H, 00H, 00H

The X axis is the first 1-4 bytes of the data field, and the Y axis is the fifth to eighth bytes of the data field, with the low byte first. The angle is expressed in points number. One point corresponds to 0.01°, and 0.01×(points-offset) is the angle. If the measuring range is +-90°, the total number of points is 18000 points. So, 0 corresponds to -90°, 18000 corresponds to +90°, and 9000 corresponds to 0°.

Take the above data frame as an example: The angle conversion process is as follows:

- 1) Get the current angle points. Note that the low byte is first, the X axis is 4650H, and the Y axis is 2023H.
- 2) Convert to decimal, X axis: 4650H→180000, Y axis: 2023H→8227.
- 3) Subtract the offset 9000 (Note: This value is an amount related to the measurement range), X axis: 180000-9000=9000, Y axis: 8227-9000=-773.
- 4) Get the final angle, X axis: 9000×0.01=90.00°, Y axis: -773×0.01=-7.73°.

Read measurement data command example 2 :												
Host sends				01 H	03 H	00 H	02 H	00 H	04 H	E5H	C9H	
Slave response												
01H	03 H	08 H	00H	00 H	00 H	00 H	00H	23 H	00H	00 H	64 H	1DH

Assuming that the measuring range of the sensor in this example is +-45°, the total number of points is 9000 points. So 0 corresponds to -45°, 9000 corresponds to +45°, 4500 corresponds to 0°, and the angle conversion process is as follows:

- 1) Get the current angle points. Note that the low byte is first, the X axis is 0000H, and the Y axis is 2300H.
- 2) Convert to decimal, X axis: 0000H→0, Y axis: 2300H→8960.
- 3) Subtract the offset of 4500 (Note: This value is an amount related to the measurement range), X axis: 0-4500=-4500, Y axis: 8960-4500=4460.
- 4) Get the final angle, X axis: -4500×0.01=-45.00°, Y axis: 4460×0.01=44.60°.

3. Set the sensor relative/absolute zero:

Modbus function code 06H

Set the sensor relative/absolute zero command :				lave response:			
Sensor address	01H	Sensor address	01H				
function code	06H	function code	06H				
Access register	00H	Access register	00H				
first address	10H	first address	10H				
If the word is non-zero, it is a relative zero point, and if it is zero, it is an absolute zero point	00 H FFH / 00H Relative / absolute	If the word is non-zero, it is a relative zero point, and if it is zero, it is an absolute zero point	00H FFH / 00H Relative / absolute				
CRC	C84FH/ 880FH	CRC	C84FH/ 880FH				

Set the sensor relative/absolute zero command example :									
Host sends			01 H	06 H	00 H	10 H	00 H	FFH	C8H 4FH
Slave response									
01 H	06 H	00 H	10 H	00 H	FFH	C8 H	4FH		

Note: 0010 is the register address. This register controls the sensor output to be relative zero or absolute zero. If it is non-zero (as in the above example, 00FFH is written), the output is relative zero. Conversely, if it is zero (change the 5th and 6th bytes to 00H), it is an absolute zero. The last two bytes are the CRC checksum.

4. Set the sensor address:

Set Sensor Address Code Command:		Slave response:	
Sensor address	01H	Sensor address	01H
function code	06H	function code	06H
address	00H	register	00H
	11H	address	11H
Sensor new address	00 H	Sensor new address	00 H
	04H		04H
CRC	D80C	CRC	D80C

Example of command to set sensor address:								
Host sends			01 H	06 H	00 H	11 H	00 H	04H D8H 0CH
Slave response								
01 H	06 H	00 H	11 H	00 H	04H	D8 H	0CH	

Note: 0011H is the register address, which controls the sensor address. In the above example, the address of the sensor is changed to 0004H, and the last two bytes are the CRC checksum.

5. Set the sensor baud rate:

Set the sensor baud rate command:		Slave response:	
Sensor address	01H	Sensor address	01H
function code	06H	function code	06H
address	00H	register	00H
	08H	address	08H
The baud rate needs to be changed	00H	The new baud rate of the sensor	00H
	A2H		A2H
CRC	89B1	CRC	89B1

Example of Set the sensor baud rate command:								
Host send			01 H	06 H	00 H	08 H	00 H	A2H 89H B1H
Slave response								
01 H	06 H	00 H	08 H	00 H	A2H	89 H	B1H	

SCA116T/SCA126T MODBUS OUTPUT INCLINOMETER

The above example is to set the baud rate to 19200, which will take effect after power on again. The factory default is: 9600bps

Note: 0008 is the register address, this register controls the sensor baud rate.

The baud rate setting corresponds to: A0H: 4800 A1H: 9600 A2H: 19200 A3H: 38400 A4: 115200

six. Set the sensor communication character format:

6. Set the sensor communication character format:

Set the sensor communication character format:		Slave response:	
Sensor address	01H	Sensor address	01H
function code	06H	function code	06H
address	00H	register	00H
	09H	address	09H
Format of sensor changing communication character	00H	New format for sensors	00H
	01H		01H
CRC	9808	CRC	9808

Example of Set the sensor communication character format point command:

Host sends	01 H	06 H	00 H	09 H	00 H	01H	98H	08H
Slave response	01 H	06 H	00 H	09 H	00 H	01H	98 H	08H

The above example is to set the byte format to: a start bit + 8 data bits without parity + 1 stop bit

It is valid after power on again. The factory default is a start bit + 8 data bits, even parity + 1 stop bit

Note: 0009 is the register address, which controls the character format of the sensor communication.

0000H: one start bit + 8 data bits, even parity + 1 stop bit

0001H: one start bit + 8 data bits without parity + 1 stop bit



Add : Block 1, COFCO(FUAN) Robotics Industrial Park ,

Da Yang Road 90, Fuyong Distict, Shenzhen City,China

Tel : (86) 755-29657137 (86) 755-29761269

Fax : (86) 755-29123494

E-mail : sales@rion-tech.net

Web : www.rionsystem.com